

Type NOZZLE DISPENSER 2X10mm S15

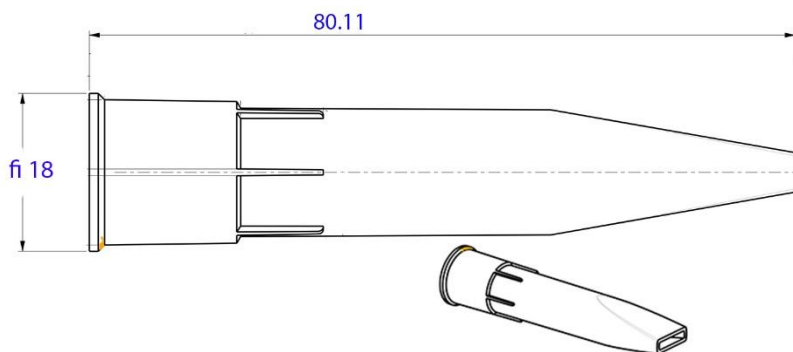

CAN BE USED FOR

chemical industry

ADVANTAGEOUS FEATURES

Used for applying adhesives, pastes, gels, greases, silicones, sealants, epoxides and other compounds in cartridges or "casing" structures.

AVAILABLE

packaging (also look blister nozzle pack)

TECHNICAL SPECIFICATION

Producer ID	PR0740-749
Producer ean code (depend on colour)	_3830065620xxxx
Raw material	PE
Type of carton	pap (5 layer)
Quantity per cardboard box [pcs] (outer box demensions 56,7 x 36,7 x 25,0 cm)	2050 pcs/box
Quantity per pallet (pallet dimension 1200 x 800 x 144 mm)	16 boxes (4 row) 32800pcs/pall
pallet height [mm]	approx. 1630
Label packaging	1 label on box 100*120mm (white) On the label will be all data known before the order conformation. All other data will be extra charge.

Packaging is standard. Other packaging types, will be charged extra.

All extra demans must be known before the order conformation.

*deviation on weight is always possible (different material, batch, etc)

Storage Before use plastic Items in production, keep them at least 24 hours indoor by 18-20°C.

It is strictly forbidden to storage pallet on pallet.

Foodsafe If you wish to have food safe certificate for our products, contact us and we will prepare it, exact for your order.

For colour variation contact office.slovenia@sopi-closures.com

All products are in tolerance according to DIN 16742 or otherwise agreed

General tolerance: DIN 16901-150